

FLEX series

Luci Power FLEX α



Luci Power FLEX α

Luci Pte., Ltd.

2017.11.14

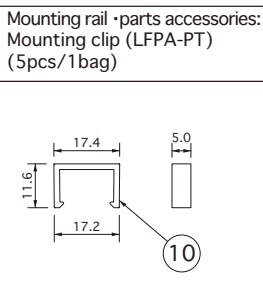
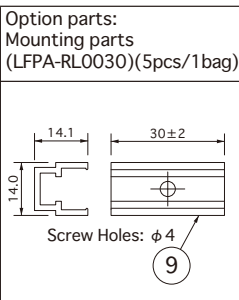
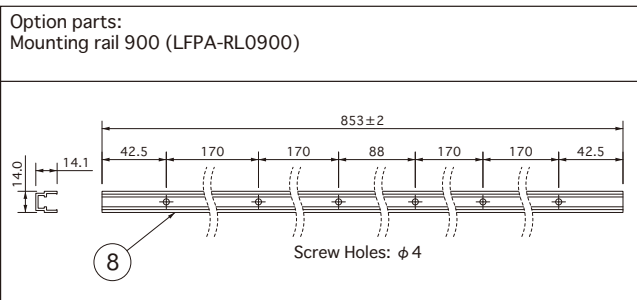
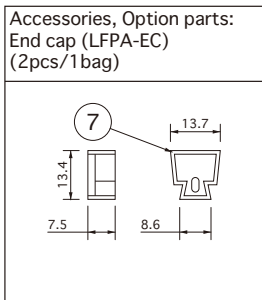
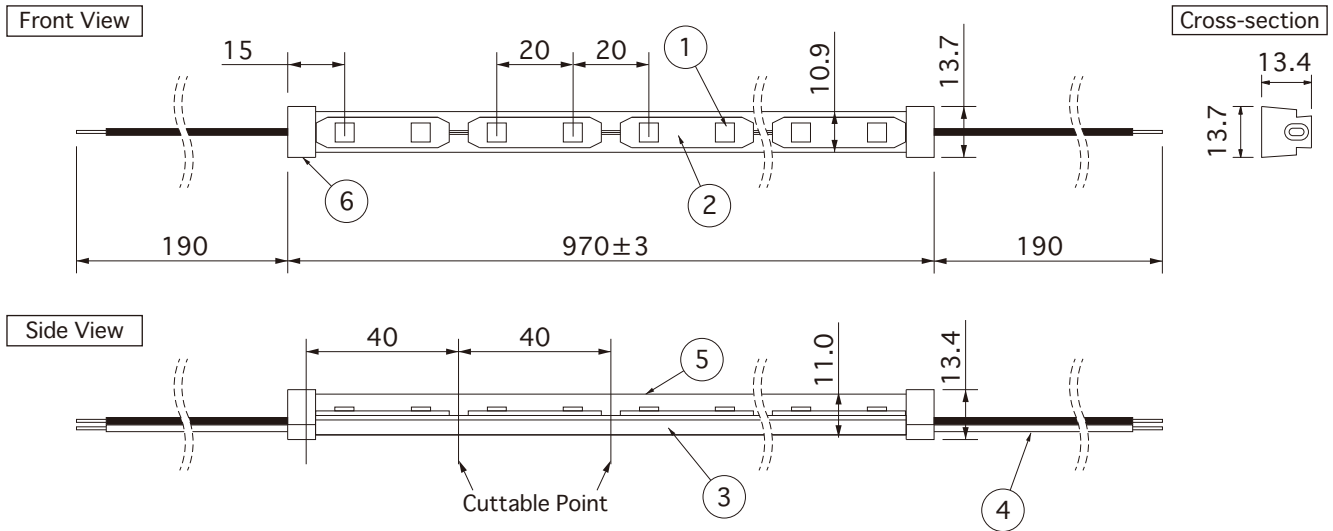

Spec · Rating may be subject to change without announcements

Unit Of Measure : mm

Part Name	Material	Note	Drawing
1 LED		SMD type	
2 LED Substrate	FR-4 (base material)	White	
3 Flexible Substrate	FPC	White	
4 Lead Wire		UL1007 AWG22 Black+, White-	
5 Body	Soft acrylic	Clear	
6 Top cap	Polycarbonate	Clear	
7 End cap	Polycarbonate	Clear	
8 Mounting rail 900	AES	White	
9 Mounting parts	AES	White	
10 Mounting clip	Polycarbonate	Clear	

Spec	Item Number
Input voltage : DC24V	LFPA20-0960-W-CL-I LFPA20-0960-WW-CL-I LFPA20-0960-L30-CL-I LFPA20-0960-L27-CL-I LFPA20-0960-L24-CL-I
Power consumption : 10W	
Weight : 60g	
Number of LEDs : 48	
Max. sets connectable : 5(5m portion)	
Min. allowable bend range : R300mm	
Environment : Indoors (No Condensation)	
Accessories : End cap×2pcs	
Option parts : Mounting rail, Mounting parts	
Mounting rail parts accessories : Mounting clip	
Light Source color : White : W : 4200K (667 lm/ Ra 90)	
Warm white 3500K : WW : 3500K (639 lm/ Ra 90)	
Warm white 3000K : L30 : 3000K (579 lm/ Ra 90)	
Warm white 2700K : L27 : 2700K (563 lm/ Ra 90)	
Warm white 2400K : L24 : 2400K (563 lm/ Ra 90)	

Job/Project Name _____ Area/Location/Circuit No. _____

Product Code _____ Qty. _____ Length(mm) _____